

Technical Rider (June 2026)

# Hear the Silence

Zoë Demoustier | laGeste

**Created** in 2026

**Premiere** 12 February 2026, at KVS - Brussels (BE)

## GENERAL

Duration and interval: 1 hour 10 minutes, no break.

*Hear the Silence* is a production featuring 8 performers and travels with 3 technicians, a tour manager and a choreographer.

The organiser must provide dressing rooms for 8 performers (separate dressing rooms for 5 women and 3 men). The dressing rooms must be equipped with sufficient chairs, lighted mirrors, power sockets, racks for hanging costumes, tables for the performers, hairdryers, easily accessible toilets and wash/shower facilities with hot and cold running water, separated for men and women. All dressing rooms must be clean and well-stocked with relevant amenities such as soap, toilet paper and towels (at least 1 towel per person).

The organiser is responsible for providing coffee, tea and water. We would appreciate it if coffee, tea, nuts, energy bars, biscuits and fruit (bananas, grapes, apples, lemons) were provided in the dressing rooms.

The organiser must provide a production office (with internet access).

If meals are served instead of a per diem: 1 vegetarian (technical crew) among the cast and 1 person with an avocado allergy. Total number of meals: 13 people, unless otherwise agreed.

The organiser will provide sufficient bottles (preferably plastic) of water for during the performance. Bottles may be placed on the table provided behind the backdrop curtain.

## **STAGE**

the organiser is responsible for the following:

- Black dance floor, 14m wide x 12m deep
- Black box: backdrop and black side panels (no legs), minimum height 6m

## **SET**

The set consists of three curtains to be hung from the existing rigging in the theatre. The curtains and their exact positions are marked on the lighting plan. On the stage right, there is a table, a piano stool and a music stand for the musician.

One fabric panel, 600mm wide and 700mm high, is suspended using steels (1100cm) and couplers on a 600mm black aluminium tube.

One fabric panel, 500mm wide and 700mm high, is suspended using steels (1100cm) and couplers on a 500mm black aluminium tube.

The third canvas is a segment of a circle and has a total length of 1300 and a height of 290. This is suspended using Reutlingers and a tube-in-tube system. Preferably, this canvas should hang freely from the rigging, unconnected to any fixed installation or lighting plan.

During the performance, these (3) flybars must be able to move; it is therefore necessary to provide an operator.

All couplers, rods and Reutlingers will be provided by laGeste, as will the aluminium tubes.

A small table, piano stool and rack will be provided by laGeste.

## **SOUND**

The sound system must be free from hum, noise or buzzing. It must provide even coverage across the various audience areas. The sound mixer must be positioned in an acoustically suitable location on the central axis of the hall, not beneath a balcony.

laGeste will provide:

- Digico SD9 sound desk
- Digico D-Rack stage rack
- Digico UBMADI sound card
- Digico Little Red Box converter
- RME Madiface sound card (Rint)

- 2 Shure shotgun microphones + stands
- 2 Rode shotgun microphones + stands
- Di Radial stereo
- 2 Shure SM58 talkback microphones
- 2 DPA 4060 beige
- 2 Ursa Small
- Revox A77

the organiser will provide the following sound equipment:

- FOH 2 left/right
- Sub 2 mono
- Rigged back speakers
- Surround speakers 2 left/right auditorium
- Top speakers 2 auditorium
- Centre cluster
- Cat 5/6 2 stage ↔ control room
- Wireless belt packs: 2 (mics + adapters by laGeste)
- Wireless handhelds: 2
- Intercom control room ↔ stage
- 10Easy sound measurement

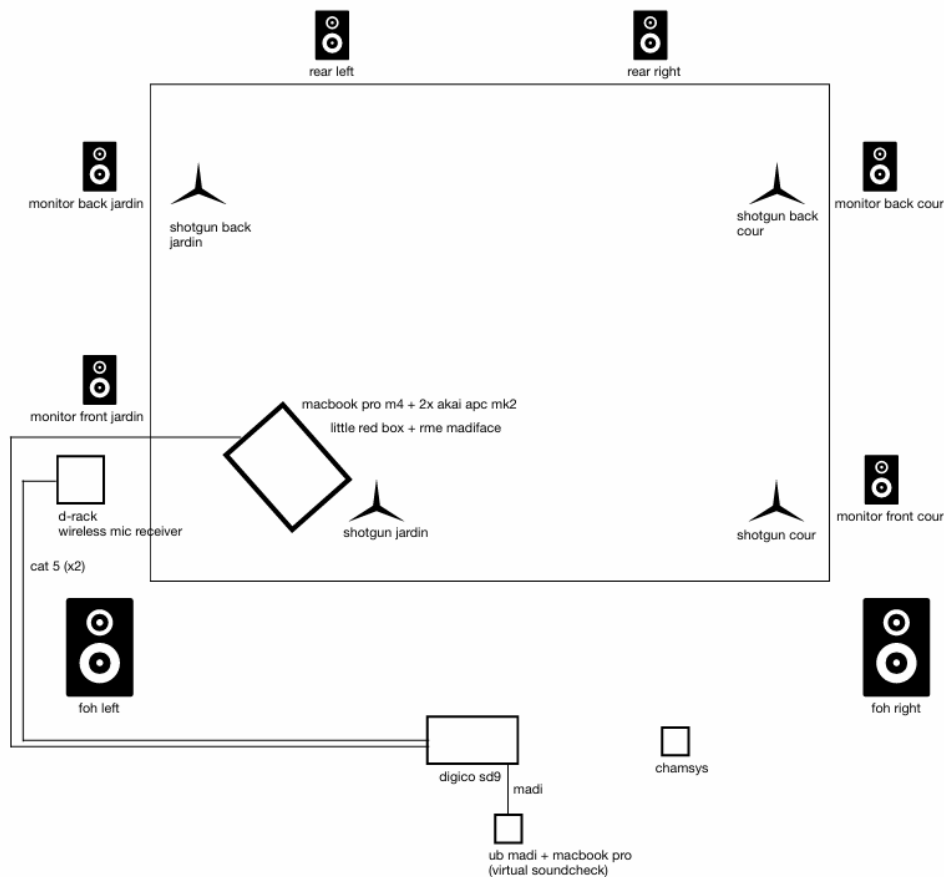

## LIGHT

laGeste will provide:

- Chamsys Wing on PC
- Low fog: Britec H2 Fog 2





the organiser will provide:

The necessary filters in accordance with the lighting plan.

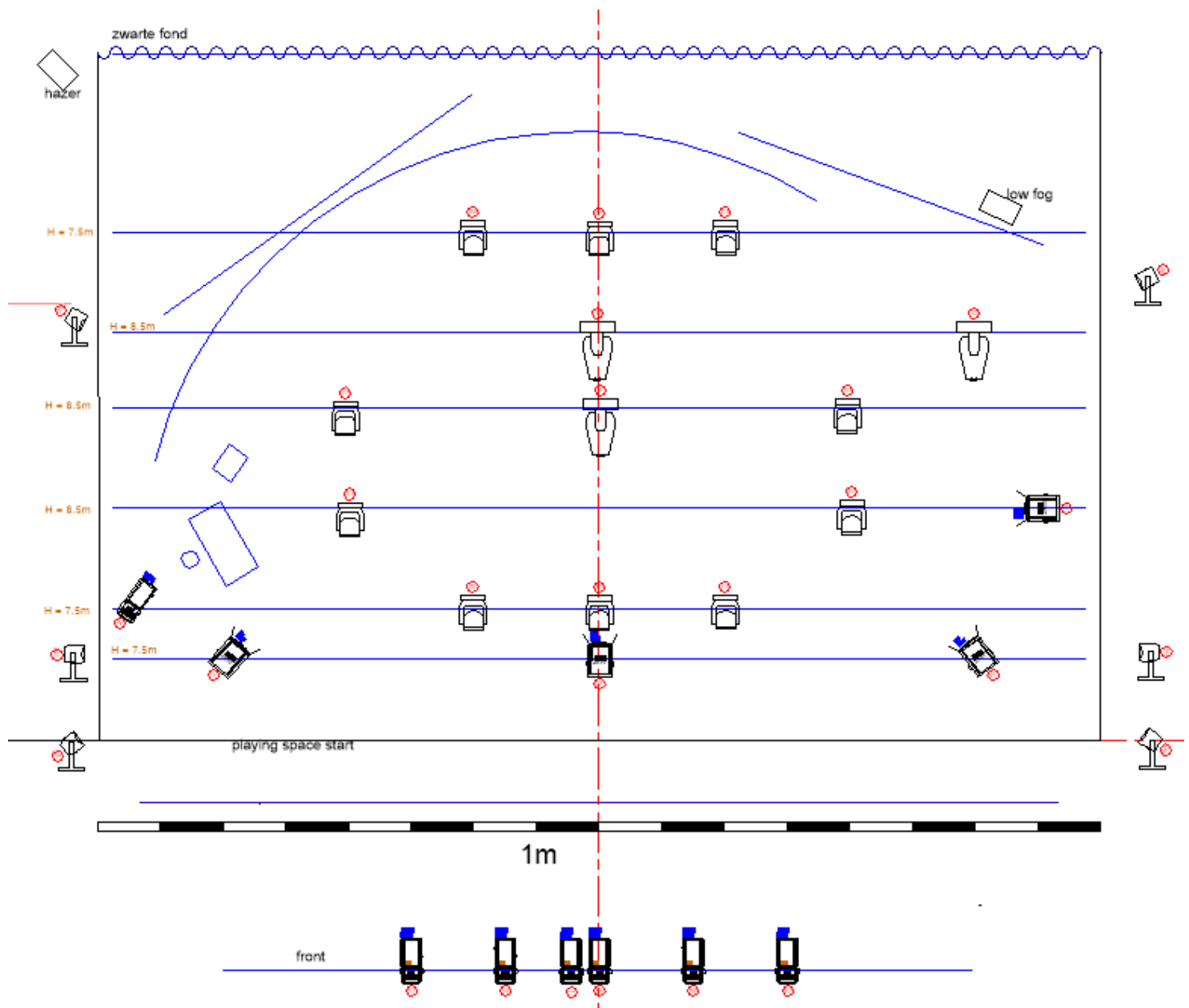
- 3 Fresnel 2kW L200
- 1 Fresnel L003 + L136
- 6 profile 2kW 15/30° L200
- 1 profile 1kW 15/30° L200
- 10 LED wash moving heads (e.g. Rober Spider 350)
- 3 LED Shaper moving heads (e.g. Chauvet Maverick Mi3)
- 6 LED par GLP Fusion (! Single source only)
- 1 hazer
- 2 fans (1 hazer, 1 low fog)
- please provide one spotlight stage right to signal the start
- please also provide lighting (blue) + a small table behind the backdrop

Lightplan - see next page:

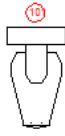

	2k Fresnel x4 L200 x3 L003 + L136 x1		LED Wash moving head x10 e.g. Robe Spider 350
	2k profile 15-30° x6 L200 x6 iris x1		LED Shaper moving head x3 e.g. Chauvet Maverick Mk3
	1k profile 15-30° x1 L200 x1		LED PAR x6 e.g. GLP Fusion (!) Single Source only

## TIMING

9.00 to 9.30 >> unload

9.30u to 13.00 >> setting up >> 1 sound, 2 light, 1 set

13.00 to 13.30 >> lunch

13.30 to 15.00 >> setting up + focus light + sound check>> 1 sound, 2 light, 1 set

15.00 >> arrival cast - spacing

18.00 >> cleaning floor/diner

20.00 >> start show

## DIVERS

The organizer must provide a secure, locked room for storing the company's costumes, props and equipment. The organizer must have the name and telephone number of a physiotherapist who is available on performance days.

Hear the Silence travels with a van. If necessary, the van will arrive the day before set-up and depart the day after dismantling. The organizer must provide a secure, locked car park for the entire period. If the technicians arrive the day before, the organizer must provide one night's hotel accommodation near the theatre.

Everything in this rider marked 'provided by the organizer' is also at the organizer's expense.

## CONTACT

Technical production

Rubben Smits

E/ [rubben@lageste.be](mailto:rubben@lageste.be)

T/ +32 474 209 516

Tour manager

Mees

E/ [mees@lageste.be](mailto:mees@lageste.be)

T/ +32 484 485 824

laGeste

Bijlokesite

Bijlokekaai 1 - 9000 Gent - België

E/ [info@lageste.be](mailto:info@lageste.be)

T/ +32 472 09 15 81

[www.lageste.be](http://www.lageste.be)